

NEET (UG) - 2025 Examination (Sunday 4th May 2025)

Expected cut off marks of NEET 2025 (15% All India Quota) : 570+ [Gen]

Expected cut off marks of NEET 2025 (Jharkhand State Quota) : 555+ [Gen]

NEET Question Paper with Answer Key

PHYSICS

1. The current passing through the battery in the given circuit, is :

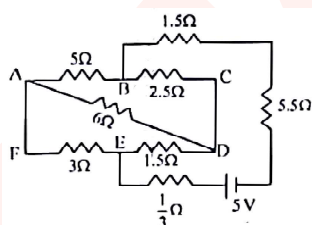

- (1) 1.5 A (2) 2.0 A
(3) 0.5 A (4) 2.5 A

Ans. 3

2. The electric field in a plane electromagnetic wave is given by

$$E_2 = 60 \cos (5x + 1.5 \times 10^9 t) V/m.$$

Then expression for the corresponding magnetic field is (here subscripts denote the direction of the field) :

- (1) $B_y = 60 \sin (5x + 1.5 \times 10^9 t) T$

(2) $B_y = 2 \times 10^{-7} \cos (5x + 1.5 \times 10^9 t) T$

(3) $B_x = 2 \times 10^{-7} \cos (5x + 1.5 \times 10^9 t) T$

(4) $B_z = 60 \cos (5x + 1.5 \times 10^9 t) T$

Ans. 2

3. The pipe open at both ends has a fundamental frequency f in air. The pipe is now dipped vertically in a water drum to half of its length. The fundamental frequency of the air column is now equal to :

(1) $2f$ (2) $\frac{f}{2}$

(3) f (4) $\frac{3f}{2}$

Ans. 3

4. An electron (mass 9×10^{-31} kg and charge 1.6×10^{-19} C) moving with speed $c/100$ (c = speed of light) is injected into a magnetic field B of magnitude 9×10^{-4} T perpendicular to its direction of motion.

We wish to apply an uniform electric field \vec{E} together with the magnetic field so that the electron does not deflect from its path. Then (speed of light $c = 3 \times 10^8 \text{ ms}^{-1}$)

(1) \vec{E} is parallel to \vec{B} and its magnitude is $27 \times 10^4 \text{ V m}^{-1}$

(2) \vec{E} is perpendicular to \vec{B} and its magnitude is $27 \times 10^4 \text{ V m}^{-1}$

(3) \vec{E} is perpendicular to \vec{B} and its magnitude is $27 \times 10^2 \text{ V m}^{-1}$

(4) \vec{E} is parallel to \vec{B} and its magnitude is $27 \times 10^2 \text{ V m}^{-1}$

Ans. 3

5. In a certain camera, a combination of four similar thin convex lenses are arranged axially in contact. Then the power of the combination and the total magnification in comparison to the power (p) and magnification (m) for each lens will be, respectively

(1) p^4 and m^4 (2) $4p$ and $4m$

(3) p^4 and $4m$ (4) $4p$ and m^4

Ans. 4

6. A 2 amp current is flowing through two different small circular copper coils having radii ratio 1:2. The ratio of their respective magnetic moments will be

(1) 4:1 (2) 1:4

(3) 1:2 (4) 2:1

Ans. 2

7. A constant voltage of 50 V is maintained between the points A and B of the circuit shown in the figure. The current through the branch CD of the circuits is :

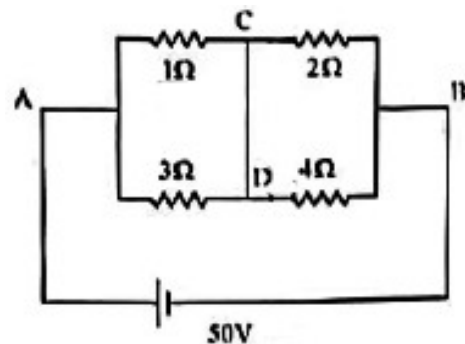

(1) 3.0 A (2) 1.5 A (3) 2.0 A (4) 2.5 A

Ans. 3

8. Two gases A and B are filled at the same pressure in separate cylinders with movable pistons of radius r_A and r_B respectively. On supplying equal amount of heat to both the systems reversibly under constant pressure, the pistons of gas A and B are displaced by 16 cm and 9 cm, respectively. If the change in their internal energy is the same,

the the ratio $\frac{r_A}{r_B}$ is equal to

(1) $\frac{\sqrt{3}}{2}$ (2) $\frac{4}{3}$

(3) $\frac{3}{4}$ (4) $\frac{2}{\sqrt{3}}$

Ans. 3

9. A container has two chambers of volumes $V_1 = 2$ litres and $V_2 = 3$ litres separated by a partition made of a thermal insulator. The chambers contains $n_1 = 5$ and $n_2 = 4$ moles of ideal gas at pressure $p_1 = 1$ atm and $p_2 = 2$ atm, respectively. When the partition is removed, the mixture attains and equilibrium pressure of :

(1) 1.8 atm (2) 1.3 atm

(3) 1.6 atm (4) 1.4 atm

Ans. 3

10. The radius of Martian orbit around the Sun is about 4 times the radius of the orbit of Mercury. The Martian year is 687 Earth days. Then which of the following is the length of 1 year on Mercury
- (1) 124 earth days (2) 88 earth days
 (3) 225 earth days (4) 172 earth days

Ans. 2

11. To an ac power supply of 220 V at 50 Hz, a resistor of 20Ω , a capacitor of reactance 25Ω and an inductor of reactance 45Ω are connected in series. The corresponding current in the circuit and the phase angle between the current and the voltage is, respectively
- (1) 15.6 A and 45° (2) 7.8 A and 30°
 (3) 7.8 A and 45° (4) 15.6 A and 30°

Ans. 3

12. A wire of resistance R is cut into 8 equal pieces. From these pieces two equivalent resistance are made by adding four of these together in parallel. Then these two sets are added in series. The net effective resistance of the combination is :

- (1) $\frac{R}{8}$ (2) $\frac{R}{64}$
 (3) $\frac{R}{32}$ (4) $\frac{R}{16}$

Ans. 4

13. The output (Y) of the given logic implementation is similar to the output of an/a _____ gate.

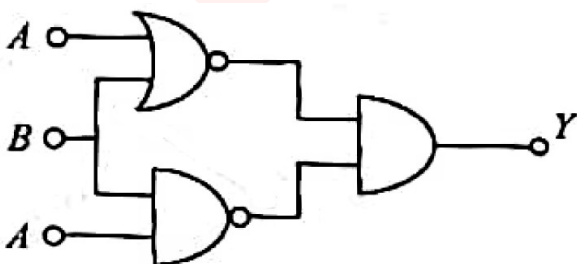

- (1) NOR (2) AND
 (3) NAND (4) OR

Ans. 1

14. Two identical charged conducting spheres A and B have their centres separated by a certain distance. Charge on each sphere is q and the force of repulsion between them is F . A third identical uncharged conducting sphere is brought in contact with sphere A first and then with B and finally removed from both. New force of repulsion between spheres A and B (radii of A and B are negligible compared to the distance of separation so that for calculation force between them they can be considered as point charges) is best given as :

- (1) $\frac{3F}{8}$ (2) $\frac{3F}{5}$
 (3) $\frac{2F}{3}$ (4) $\frac{F}{2}$

Ans. 1

15. Consider the diameter of a spherical object being measured with the help of a Vernier callipers. Suppose its 10 Vernier Scale Divisions (V.S.D.) are equal to its 9 Main Scale Divisions (M.S.D.). The least division in the M.S. is 0.1 cm and the zero of V.S. is at $x = 0.1$ cm when the jaws of Vernier callipers are closed.

If the main scale reading for the diameter is $M = 5$ cm and the number of coinciding vernier division is 8, the measured diameter after zero error correction, is

- (1) 5.00 cm (2) 5.18 cm
 (3) 5.08 cm (4) 4.98 cm

Ans. 4

16. In some appropriate units, time (t) and position (x) relation of a moving particle is given by $t = x^2 + x$. The acceleration of the particle is

(1) $+\frac{2}{2x+1}$ (2) $-\frac{2}{(x+2)^3}$
 (3) $-\frac{2}{(2x+1)^3}$ (4) $+\frac{2}{(x+1)^3}$

Ans. 3

17. Which of the following options represent the variation of photoelectric current with property of light shown on the x -axis ?

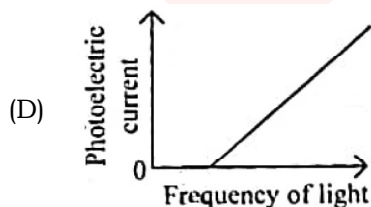
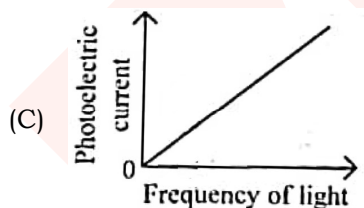
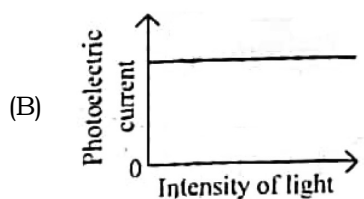
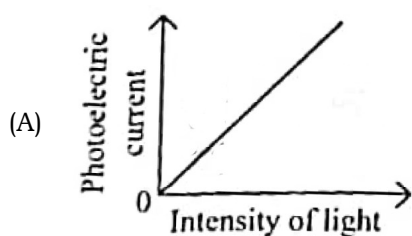

- (1) B and D (2) A only
 (3) A and C (4) A and D

Ans. 2

18. A particle of mass m is moving around the origin with a constant force F pulling it towards the origin. If Bohr model is used to describe its motion, the radius r of the n^{th} orbit and the particle's speed in the orbit depend on n as

(1) $r \propto n^{4/3}; v \propto n^{1/3}$
 (2) $r \propto n^{1/3}; v \propto n^{1/3}$
 (3) $r \propto n^{1/3}; v \propto n^{2/3}$
 (4) $r \propto n^{2/3}; v \propto n^{1/3}$

Ans. 4

19. A bob of heavy mass m is suspended by a light string of length l . The bob is given a horizontal velocity v_0 as shown in figure. If the string gets slack at some point P making an angle θ from the horizontal, the ratio of the speed v of the bob at point P to its initial speed v_0 is :

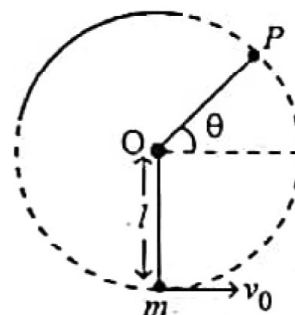

(1) $\left(\frac{\sin \theta}{2+3 \sin \theta}\right)^{1/2}$ (2) $(\sin \theta)^{1/2}$
 (3) $\left(\frac{1}{2+3 \sin \theta}\right)^{1/2}$ (4) $\left(\frac{\cos \theta}{2+3 \sin \theta}\right)^{1/2}$

Ans. 1

20. A full wave rectifier circuit with diodes (D_1) and (D_2) is shown in the figure. If input supply voltage $V_{in} = 220 \sin(100\pi t)$ volt, then at $t = 15 \text{ m sec}$.

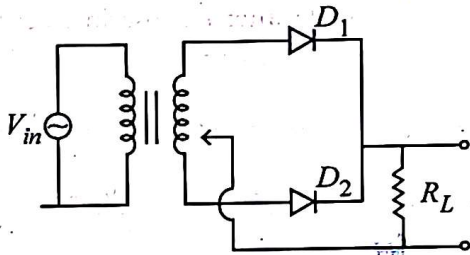

- (1) D_1 and D_2 both are reverse biased
- (2) D_1 is forward biased, D_2 is reverse biased
- (3) D_1 is reverse biased, D_2 is forward biased
- (4) D_1 and D_2 both are forward biased

Ans. 3

21. A balloon is made of a material of surface tension S and its inflation outlet (from where gas is filled in it) has small area A . It is filled with a gas of density r and takes a spherical shape of radius R . When the gas is allowed to flow freely out of it, its radius ρ changes from R to 0 (zero) in time T . If the speed $v(r)$ of gas coming out of the balloon depends on r as r^a and $T \propto S^{\alpha} A^{\beta} \rho^{\gamma} R^{\delta}$ then

- (1) $a = \frac{1}{2}, \alpha = \frac{1}{2}, \beta = -\frac{1}{2}, \gamma = \frac{1}{2}, \delta = \frac{7}{2}$
- (2) $a = \frac{1}{2}, \alpha = \frac{1}{2}, \beta = -1, \gamma + 1, \delta = \frac{3}{2}$
- (3) $a = -\frac{1}{2}, \alpha = -\frac{1}{2}, \beta = -1, \gamma = -\frac{1}{2}, \delta = \frac{5}{2}$
- (4) $a = -\frac{1}{2}, \alpha = -\frac{1}{2}, \beta = -1, \gamma = \frac{1}{2}, \delta = \frac{7}{2}$

Ans. 4

22. A microscope has an objective of focal length 2 cm, eyepiece of focal length 4 cm and the tube length of 40 cm. If the distance of distinct vision of eye is 25 cm, the magnification in the microscope is

- (1) 250
- (2) 100
- (3) 125
- (4) 150

Ans. 3

23. Two identical point masses P and Q , suspended from two separate massless springs of spring constants k_1 and k_2 respectively, oscillate vertically. If their maximum speeds are the same, the ratio (A_Q / A_P) of the amplitude A_Q of mass Q to the amplitude A_P of mass P is

- (1) $\sqrt{\frac{k_1}{k_2}}$
- (2) $\frac{k_2}{k_1}$
- (3) $\frac{k_1}{k_2}$
- (4) $\sqrt{\frac{k_2}{k_1}}$

Ans. 1

24. A parallel plate capacitor made of circular plates is being charged such that the surface charge density on its plates is increasing at a constant rate with time. The magnetic field arising due to displacement current is :

- (1) zero between the plates and non-zero outside
- (2) zero at all places
- (3) constant between the plates and zero outside the plates
- (4) non-zero everywhere with maximum at the imaginary cylindrical surface connecting peripheries of the plates

Ans. 4

25. An electric dipole with dipole moment $5 \times 10^{-6} \text{ cm}$ is aligned with the direction of a uniform electric field of magnitude $4 \times 10^5 \text{ N/C}$. The dipole is then rotated through an angle of 60° with respect to the electric field. The change in the potential energy of the dipole is :

- (1) 1.5 J (2) 0.8 J
 (3) 1.0 J (4) 1.2 J

Ans. 3

26. There are two inclined surfaces of equal length (L) and same angle of inclination 45° with the horizontal. One of them is rough and the other is perfectly smooth. A given body takes 2 times as much time to slide down on rough surface than on the smooth surface. The coefficient of kinetic friction (μ_k) between the object and the rough surface is close to

- (1) 0.75 (2) 0.25
 (3) 0.40 (4) 0.5

Ans. 1

27. De-Broglie wavelength of an electron orbiting in the $n = 2$ state of hydrogen atom is close to (Given Bohr radius = 0.052 nm)

- (1) 2.67 nm (2) 0.067 nm
 (3) 0.67 nm (4) 1.6 nm

Ans. 3

28. The Sun rotates around its once in 27 days. What will be the period of revolution if the Sun were to expand to twice its present radius without any external influence ? Assume the Sun to be a sphere of uniform density

- (1) 108 days (2) 100 days
 (3) 105 days (4) 115 days

Ans. 1

29. A physical quantity P is related to four observations a, b, c and d as follows : $P = \frac{a^3 b^2}{c \sqrt{d}}$

The percentage errors of measurement in a, b, c and d are 1%, 3%, 2% and 4% respectively. The percentage error in the quantity P is

- (1) 15% (2) 10%
 (3) 2% (4) 13%

Ans. 4

30. The plate of a parallel plate capacitor are separated by two slabs of different dielectric constant K_1 and K_2 with thickness $\frac{3}{8}d$ and $\frac{d}{2}$ respectively are inserted in the capacitor. Due to this the capacitance becomes two times large than when there is nothing between the plates

If $K_1 = 1.25 K_2$, the value of K_1 is :

- (1) 1.33 (2) 2.66
 (3) 2.33 (4) 1.60

Ans. 2

31. A ball of mass 0.5 kg is dropped from a height of 40 m . The ball hits the ground and rises to a height of 10 m . The impulse imparted to the ball during its collision with the ground is

(Take $g = 9.8 \text{ m/s}^2$)

- (1) 84 NS (2) 21 NS
 (3) 7 NS (4) 0

Ans. 2

32. Two cities X and Y are connected by a regular bus service with a bus leaving in either direction every T min. A girl is driving scooter with a speed of 60 km/h in the direction X to Y notices that a bus goes past her every 30 minutes in the direction of her motion and every 10 minutes in the opposite direction. Choose the correct option for the period T of the bus service and the speed (assumed constant) of the buses
 (1) 15 min 120 km/h (2) 9 min 40 km/h
 (3) 25 min. 100 km/h (4) 10 min 90 km/h

Ans. 1

33. An oxygen cylinder of volume 30 litre has 18.20 moles of oxygen. After some oxygen is withdrawn from the cylinder. Its gauge pressure drops to 11 atmospheric pressure at temperature 27°C . The mass of the oxygen withdrawn from the cylinder is nearly equal to :

(Given $R = \frac{100}{12} \text{ J mol}^{-1} \text{ K}^{-1}$ and molecular mass

of $\text{O}_2 = 32$. 1atm pressure = $1.01 \times 10^5 \text{ N/m}^2$]

- (1) 0.156 kg (2) 0.125 kg
 (3) 0.144 kg (4) 0.116 kg

Ans. 4

34. AB is part of an electrical circuit (see figure). The potential difference ' $V_A - V_B$ ' at the instant when current $i = 2\text{A}$ and its increasing at a rate of 1 amp/second is :

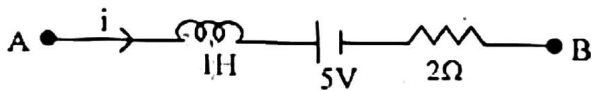

- (1) 10 volt (2) 5 volt
 (3) 6 volt (4) 9 volt

Ans. 1

35. In an oscillating spring mass system, a spring is connected to a box filled with sand. As the box oscillates sand leaks slowly out of the box vertically so that the average frequency $\omega(t)$ and average amplitude $A(t)$ of the system change with time t . Which one of the following option schematically depicts these changes correctly ?

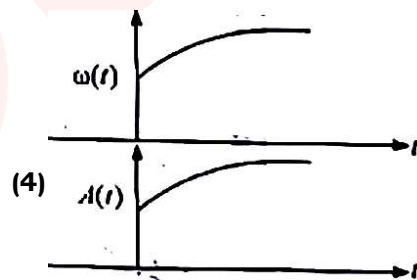
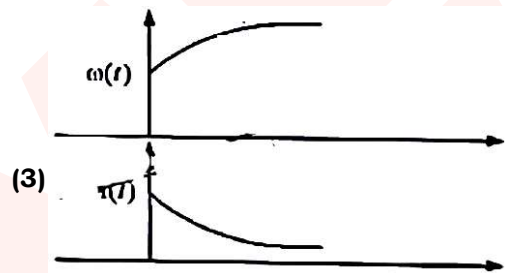
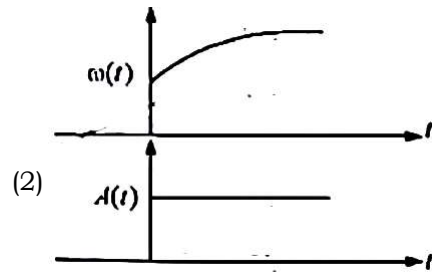
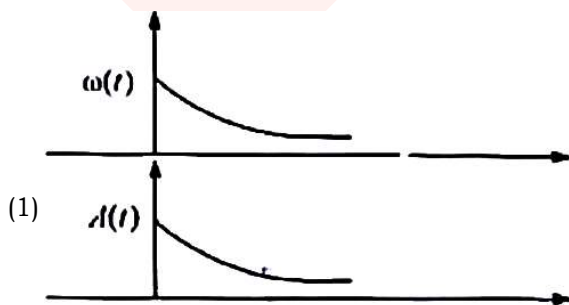

Ans. 3

36. A model of quantized motion of an electron in an uniform magnetic field B states that the flux passing through the orbit of the electron is $n(h/e)$ where n is an integer, h is Planck's constant and e is the magnitude of electron's charge. According to the model, the magnetic moment of an electron in its lowest energy state will be (m is the mass of the electron)

- (1) $\frac{heB}{2\pi m}$ (2) $\frac{he}{\pi m}$
 (3) $\frac{he}{2\pi m}$ (4) $\frac{heB}{\pi m}$

Ans. 3

37. A body weight 48N on the surface of the earth. The gravitational force experienced by the body due to the earth at a height equal to one third the radius of the earth from its surface is :

- (1) 36 N (2) 16 N
(3) 27 N (4) 32 N

Ans. 3

38. Consider a water tank shown in the figure. It has one wall at $x = L$ and can be taken to be very wide in that z direction. When filled with a liquid of surface tension S and density ρ , the liquid surface makes angle θ_0 ($0_0 \ll 1$) with the x -axis $x = L$. If $y(x)$ is the height of the height of the surface then the equation for $y(x)$ is

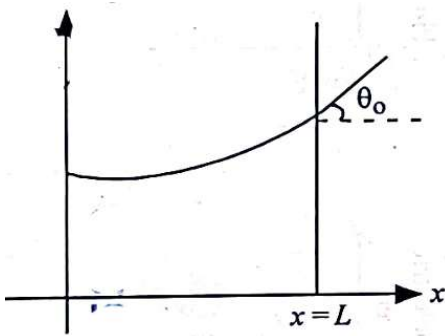

(take $\theta(x) = \sin \theta(x) = \tan(x) = \frac{dy}{dx}$, g is the acceleration due to gravity)

(1) $\frac{dy}{dx} = \sqrt{\frac{\rho g}{s}} x$ (2) $\frac{d^2 y}{dx^2} = \frac{\rho g}{S} x$

(3) $\frac{d^2 y}{dx^2} = \frac{\rho g}{s} y$ (4) $\frac{d^2 y}{dx^2} = \sqrt{\frac{\rho g}{s}}$

Ans. 3

39. The intensity of transmitted light when a polaroid sheet, placed between two crossed polaroids at 22.5° from the polarization axis of one of the polaroid, is (I_0 is the intensity of

polarised light after passing through the first polaroids) :

(1) $\frac{I_0}{16}$ (2) $\frac{I_0}{2}$

(3) $\frac{I_0}{4}$ (4) $\frac{I_0}{8}$

Ans. 4

40. A photon and an electron (mass m) have the same energy E . The ratio ($\lambda_{\text{photon}} / \lambda_{\text{electron}}$) of their de Broglie wavelengths is (c is the speed of light)

(1) $\frac{1}{c} \sqrt{E/2m}$ (2) $\sqrt{\frac{E}{2m}}$

(3) $c\sqrt{2mE}$ (4) $\sqrt{\frac{2m}{E}}$

Ans. 4

41. An unpolarised light beam travelling in air is incident on a medium of refractive index 1.73 at Brewster's angle. then

- (1) Transmitted light is completely polarized with angle of refraction close to 30°
(2) reflected light is completely polarised and the angle of reflection is close to 60°
(3) reflected light partially polarized and the angle of reflection is close to 30°
(4) both reflected and transmitted light are perfectly polarised with angles of reflection and refraction close to 60° and 30° respectively

Ans. 2

42. A uniform rod of mass 20 kg and length 5m leans against a smooth vertical wall making an angle of 60° with it. The other end rests on a rough horizontal floor. The friction force that the floor exerts on the rod is (take $g = 10 \text{ m/s}^2$)

(1) $200\sqrt{3} \text{ N}$ (2) 100 N

(3) $100\sqrt{3} \text{ N}$ (4) 200 N

Ans. 3

43. Three identical heat conducting rods are connected in series as shown in the figure. The rods on the sides have thermal conductivity $2K$ while that in the middle has thermal conductivity K . The left end of the combination is maintained at temperature $3T$ and the right end at T . The rods are thermally insulated from outside. In steady state, temperature at the left junction is T_1 and that at the right junction is T_2 . The ratio T_1/T_2 is

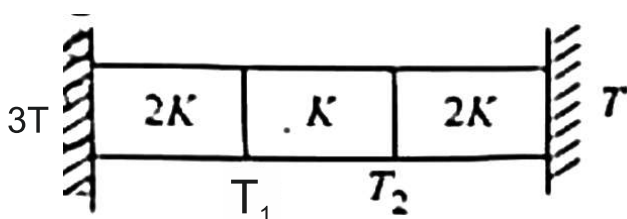

- (1) $\frac{5}{4}$ (2) $\frac{3}{2}$
 (3) $\frac{4}{3}$ (4) $\frac{5}{3}$

Ans. 4

44. The kinetic energies of two similar cars A and B are 100 J and 225 J respectively. On applying breaks car A stops after 1000m and car stops after 1500m. If F_A and F_B are the force applied by the breaks on cars A and B, respectively then the ratio F_A/F_B is

- (1) $\frac{1}{2}$ (2) $\frac{3}{2}$
 (3) $\frac{2}{3}$ (4) $\frac{1}{3}$

Ans. 3

45. A sphere of radius R is cut from a larger solid sphere radius $2R$ as shown in the figure. The ratio of the moment of inertia of the smaller sphere to that of the rest part of the sphere about the Y-axis is

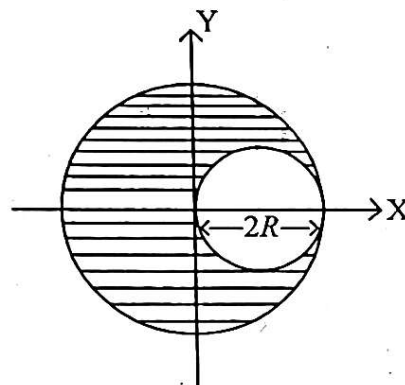

- (1) $\frac{7}{4}$ (2) $\frac{7}{8}$
 (3) $\frac{7}{40}$ (4) $\frac{7}{57}$

Ans. 4

CHEMISTRY

46. If the molar conductivity (Λ_m) of a 0.050 mol /L solution of a monobasic weak acid is $90 \text{ S cm}^2 \text{ mol}^{-1}$. its extent (degree) of dissociation will be [Assume $\Lambda_+^\circ = 349.6 \text{ S cm}^2 \text{ mol}^{-1}$ and $\Lambda_-^\circ = 50.4 \text{ S cm}^2 \text{ mol}^{-1}$]
- (1) 0.215 (2) 0.115
 (3) 0.125 (4) 0.225

Ans. 4

47. Given below are two statements :
- Statement – I : A hypothetical diatomic molecule with bond order zero is quite stable.
- Statement – II : As bond order increases, the bond length increases
- In the light of the above statements, choose the most appropriate answer from the options given below
- (1) Statement I is false but statement II is true
 (2) Both Statement I and Statement II are true
 (3) Both Statement I and Statement II are false
 (4) Statement I is true but statement II is false

Ans. 3

48. The ratio of the wavelengths of the light absorbed by Hydrogen atom when it undergoes $n = 2 \rightarrow n = 3$ and $n = 4 \rightarrow n = 6$ transition, respectively is

- (1) $\frac{1}{4}$ (2) $\frac{1}{36}$
 (3) $\frac{1}{16}$ (4) $\frac{1}{9}$

Ans. 1

49. The correct order of the wavelength of light absorbed by the following complex is

- (A) $[\text{Co}(\text{NH}_3)_6]^{+3}$ (B) $[\text{Co}(\text{CN})_6]^{3-}$
 (C) $[\text{Cu}(\text{H}_2\text{O})_4]^{2+}$ (D) $[\text{Ti}(\text{H}_2\text{O})_6]^{3+}$

Choose the correct answer from the options given below:

- (1) $C < A < D < B$ (2) $B < D < A < C$
 (3) $B < A < D < C$ (4) $C < D < A < B$

Ans. 3

50. If the rate constant of a reaction is 0.03 s^{-1} how much time does it take for 7.2 mol L^{-1} concentration of the reactant to get reduced to 0.9 mol L^{-1} ? (Given : $\log 2 = 0.301$)

- (1) 21.0 s
 (2) 69.3 s
 (3) 23.1 s
 (4) 210 s

Ans. 2

51. Match List I with List II

- | List I | List II |
|--|---|
| A. $\text{CHCl}_3 + \text{C}_6\text{H}_5\text{NH}_2$ | (I) Distillation under reduced pressure |
| B. Crude oil in petroleum industry | (II) Steam distillation |
| C. Glycerol from spet - lye | (III) Fractional distillation |
| D. Aniline - water | (IV) Simple distillation |

Choose the correct answer from the options given below :

- (1) A - III, B - IV, C - II, D - I
 (2) A - IV, B - III, C - I, D - II
 (3) A - IV, B - III, C - II, D - I
 (4) A - III, B - IV, C - I, D - II

Ans. 2

52. The major product of the following reaction is :

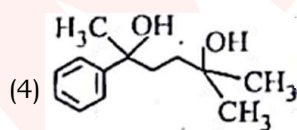
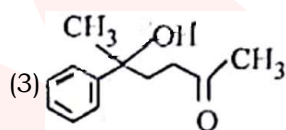
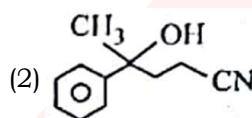
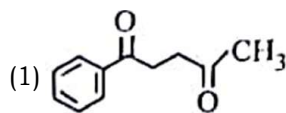
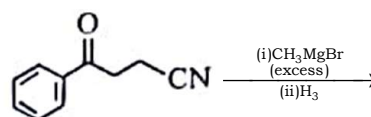

Ans. 3

53. Which one of the following compounds can exist as cis - trans isomers ?

- (1) 1, 2 - Dimethylcyclohexane
 (2) Pent - 1 - ene
 (3) 2 - Methylhex - 2 - ene
 (4) 1, 1 - Dimethylcyclopropane

Ans. 1

54. Among the following, choose the ones with equal number of atoms.

- A. 212 g of $\text{Na}_2\text{CO}_3(\text{s})$ [molar mass = 106 g]
 B. 248 g of $\text{Na}_2\text{O}(\text{s})$ [molar mass = 62 g]
 C. 240 g of $\text{NaOH}(\text{s})$ [molar mass = 40 g]
 D. 12 g of $\text{H}_2(\text{g})$ [molar mass = 2 g]
 E. 220 g of $\text{CO}_2(\text{s})$ [molar mass = 44 g]

Choose the correct answer from the options given below

- (1) B, D, and E only
 (2) A, B and C only
 (3) A, B and D only
 (4) B, C and D only

Ans. 3

55. Among the given compounds I – III, the correct order of bond dissociation energy of C – H bond marked with * is :

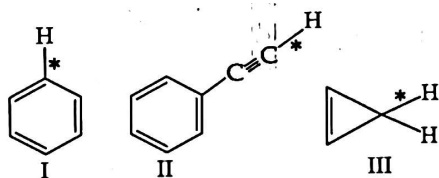

- (1) II > III > I
 (2) II > I > III
 (3) I > II > III
 (4) III > II > I

Ans. 2

56. The standard heat of formation, in kcal/mol of Ba^{2+} is :

[Given : Standard heat of formation of SO_4^{2-} ion(aq) = -216 kcal/mol,

Standard heat of crystallisation of

BaSO_4 (s) = - 4.5 kcal/mol, standard heat of formation of BaSO_4 (s) = - 349 kcal/mol]

- (1) + 220.5 (2) - 128.5
 (3) - 133.0 (4) + 133.0

Ans. 2

57. Consider the following compounds :

$\underline{\text{K}}\text{O}_2$, $\text{H}_2\underline{\text{O}}_2$ and $\text{H}_2\underline{\text{S}}\text{O}_4$.

The oxidation states of the underlined elements in them are, respectively,

- (1) + 4, - 4, and + 6
 (2) + 1, - 1, and + 6
 (3) + 2, - 2, and + 6
 (4) + 1, - 2, and + 4

Ans. 2

58. Out of the following complex compounds, which of the compounds will be having the minimum conductance in solution ?

- (1) $[\text{Co}(\text{NH}_3)_5\text{Cl}]\text{Cl}$
 (2) $[\text{Co}(\text{NH}_3)_3\text{Cl}_3]$
 (3) $[\text{Co}(\text{NH}_3)_4\text{Cl}_2]$
 (4) $[\text{Co}(\text{NH}_3)_6]\text{Cl}_3$

Ans. 2 & 3

59. Which one of the following reactions does NOT give benzene as the product ?

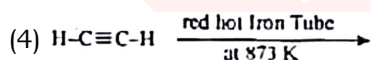
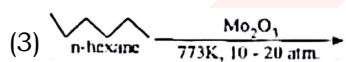
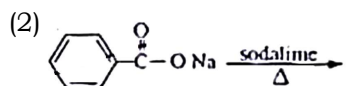
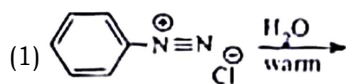

Ans. 1

60. Which of the following are paramagnetic ?

- A. $[\text{NiCl}_4]^{2-}$ B. $\text{Ni}(\text{CO})_4$
 C. $[\text{Ni}(\text{CN})_4]^{2-}$ D. $[\text{Ni}(\text{H}_2\text{O})_6]^{2+}$
 E. $\text{Ni}(\text{PPh}_3)_4$

Choose the correct answer from the options given below :

- (1) A, D, and E only
 (2) A and C only
 (3) B and E only
 (4) A and D only

Ans. 4

61. Which one of the following compounds does not decolourize bromine water ?

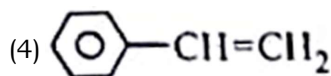
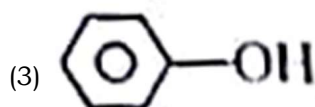
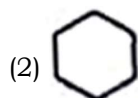
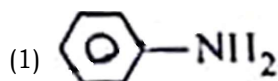

Ans. 2

62. Match List - I with List - II
- | | |
|-----------------------|--|
| List - I | List - II |
| A. Haber process | I. Fe catalyst |
| B. Waeker oxidation | II. PdCl ₂ |
| C. Wilkinson catalyst | III. [(PPh ₃) ₃ RhCl] |
| D. Ziegler catalyst | IV. TiCl ₄ with Al(CH ₃) ₃ |

Choose the correct answer from the options given below :

- (1) A - I, B - IV, C - III, D - II
 (2) A - I, B - II, C - IV, D - III
 (3) A - II, B - III, C - I, D - IV
 (4) A - I, B - II, C - III, D - IV

Ans. 4

63. Match List I with List II.

List - I	List - II
(Name of Vitamin)	(Deficiency disease)
A. Vitamin B ₁₂	I. Cheilosis
B. Vitamin D	II. Convulsions
C. Vitamin B ₂	III. Rickets
D. Vitamin B ₆	IV. Pernicious anaemia

Choose the correct answer from the options given below

- (1) A - IV, B - III, C - II, D - I
 (2) A - I, B - III, C - II, D - IV
 (3) A - IV, B - III, C - I, D - II
 (4) A - II, B - III, C - I, D - IV

Ans. 3

64. Given below are two statements :

Statement I : Ferromagnetism is considered as an extreme form of paramagnetism.

Statement - II : The number of unpaired electrons in a Cr²⁺ ions (Z = 24) is the same as that of a Nd³⁺ ion (Z = 60)

In the light of the above statements, choose the correct answer from the options given below :

- (1) Statement I is false but statement II is true
 (2) Both Statement I and Statment II are true
 (3) Both Statement I and Statement II are false
 (4) Statement I is true but statement II is fals

Ans. 4

65. If the half - life (t_{1/2}) for a first order reaction is 1 minute, then the time required for 99.9% completion of the reaction is closest to :

- (1) 10 minutes (2) 2 minutes
 (3) 4 minutes (4) 5 minutes

Ans. 1

66. The correct order of decreasing basic strength of the given amines is :

- (1) benzenamine > ethanmine > N - methylaniline > N - ethylethanamine
 (2) N - methylaniline > benzenamine > ethanamine > N - ethylethanamine
 (3) N - ethylethanamine > ethanamine > benzenamine > N - methylaniline
 (4) N - ethyethanamine > ethanamine > N - methylaniline > benzenamine

Ans. 4

67. Match List I with List II

List - I	List - II (Group Number in Cation Analysis)
(Ion)	
A. Co ²⁺	I. Group - I
B. Mg ²⁺	II. Group - III
C. Pb ²⁺	III. Group - IV
D. Al ³⁺	IV. Group - VI

Choose the correct answer from the options given below :

- (1) A - III, B - II, C - I, D - IV
 (2) A - III, B - IV, C - II, D - I
 (3) A - III, B - IV, C - I, D - II
 (4) A - III, B - II, C - IV, D - I

Ans. 3

68. Phosphoric acid ionizes in three steps with their ionization constant values

K_{a1}, K_{a2} and K_{a3}, respectively,

while K is the overall ionization constant.

Which of the following statements are true ?

- A. $\log K = \log K_{a1} + \log K_{a2} + \log K_{a3}$
 B. H₃PO₄ is a stronger acid than H₂PO₄⁻ and HPO₄²⁻
 C. $K_{a1} > K_{a2} > K_{a3}$
 D. $K_{a1} = \frac{K_{a3} + K_{a2}}{2}$

Choose the correct answer from the options given below :

- (1) A, B and C only
 (2) A and B only
 (3) A and C only
 (4) B, C and D only

Ans. 1

69. Which of the following statements are true ?
- Unlike Ga that has a very high melting points Cs has a very low melting point
 - On Pauling scale, the electronegativity value of N and Cl are not the same
 - Ar, K⁺, Cl⁻, Ca²⁺ and S²⁻ are all isoelectronic species.
 - The correct order of the first ionization enthalpies of Na, Mg, Al and Si is Si > Al > Mg > Na
 - The atomic radius of Cs is greater than that of Li and Rb
- Choose the correct answer from the options given below :
- A, C and E only
 - A, B and E only
 - C and E only
 - C and D only

Ans. 3

70. Given below are two statements:
- Statement I : Like nitrogen that can form ammonia, arsenic can form arsine.
- Statement II: Antimony cannot form antimony pentoxide.
- Both Statement I and Statement II are incorrect
 - Statement I is correct but Statement II is incorrect
 - Both Statement I and Statement II are incorrect
 - Statement I is correct but Statement II is incorrect

Ans. 4

71. Which of the following aqueous solution will exhibit highest boiling point?
- 0.015 M C₆H₁₂O₆
 - 0.01 M Urea
 - 0.01 M KMO₃
 - 0.01 M Na₂SO₄

Ans. 4

72. Given below are two statements:
- Statement I : Benzenediazonium salt is prepared by the reaction of aniline with nitrous acid at 273 - 278 K. It decomposes easily on the dry

state.

Statement II: Insertion of iodine into the benzene ring is difficult and hence iodobenzene is prepared through the reaction of benzenediazonium salt with KI.

In the light of the above statements, choose the most appropriate answer from the options given below :

- Statement I is incorrect but statement II is correct
- Both Statement I and Statement II are correct
- Both Statement I and Statement II are incorrect
- Statement I is correct but Statement II is incorrect

Ans. 2

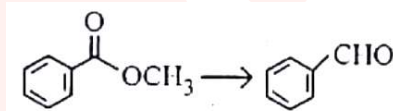

73. Identify the suitable reagent for the following conversion.



- H₂ / Pd - BaSO₄
- (i) LiAlH₄, (ii) H⁺ / H₂O
- (i) AlH(iBu)₂, (ii) H₂O
- (i) NaBH₄, (ii) H⁺ / H₂O

Ans. 3

74. Given below are two statements: One is labelled as Assertion (A) and the other is labelled as Reason (R).

Assertion (A):  undergoes S_N2 reaction faster than  Cl.

Reason (R) : Iodine is a better leaving group because of its large size.

In the light of the above statement, choose the correct answer from the options given below:

- A is false but R is true
- Both A and R are true and R is the correct explanation of A
- Both A and R are true but R is not the correct explanation of A
- A is true but R is false

Ans. 2

75. The correct order of decreasing acidity of the following aliphatic acids is:

- (1) $\text{HCOOH} > (\text{CH}_3)\text{CCOOH} > (\text{CH}_3)_3\text{CCOOH} > \text{CH}_3\text{COOH}$
 (2) $(\text{CH}_3)_3\text{CCOOH} > (\text{CH}_3)_2\text{CHCOOH} > \text{CH}_3\text{COOH} > \text{HCOOH}$
 (3) $\text{CH}_3\text{COOH} > (\text{CH}_3)_2\text{CHCOOH} > (\text{CH}_3)_3\text{CCOOH} > \text{HCOOH}$
 (4) $\text{HCOOH} > \text{CH}_3\text{COOH} > (\text{CH}_3)_2\text{CHCOOH} > (\text{CH}_3)_3\text{CCOOH}$

Ans. 4

76. Which one of the following reaction does NOT belong to Lassaigne's test?

- (1) $2\text{CuO} + \text{C} \xrightarrow{\Delta} 2\text{Cu} + \text{CO}_2$
 (2) $\text{Na} + \text{C} + \text{N} \xrightarrow{\Delta} \text{NaCN}$
 (3) $2\text{Na} + \text{S} \xrightarrow{\Delta} \text{Na}_2\text{S}$
 (4) $\text{Na} + \text{X} \xrightarrow{\Delta} \text{NaX}$

Ans. 1

77. How many products (including stereoisomers) are expected from monochlorination of the following compound?

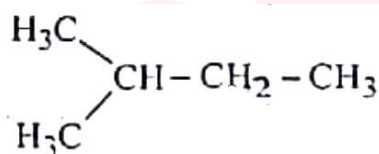

- (1) 6 (2) 2
 (3) 3 (4) 5

Ans. 1

78. Sugar 'X'

- A. is found in honey
 B. is a keto sugar
 C. exists in α and β anomeric forms.
 D. is laevorotatory

'X' is:

- (1) Sucrose (2) D-Glucose
 (3) D-Fructose (4) Maltose

Ans. 3

79. Dalton's atomic theory could not explain which of the following?

- (1) Law of gaseous volume
 (2) Law of conservation of mass
 (3) Law of constant proportion
 (4) Law of multiple proportion

Ans. 1

80. Higher yield of NO in

$\text{N}_2(\text{g}) + \text{O}_2(\text{g}) \rightleftharpoons 2\text{NO}(\text{g})$ can be obtained at
 [ΔH of the reaction = + 180.7 kJ mol⁻¹]

- A. higher temperature
 B. lower temperature
 C. higher concentration of N_2
 D. higher concentration of O_2

Choose the correct answer from the options given below:

- (1) A, C, D only (2) A, D only
 (3) B, C only (4) B, C, D only

Ans. 1

81. Match List - I with List - II

List-I

List-II

- | | |
|--------------------|---|
| A. XeO_3 | I. sp^3d ; linear |
| B. XeF_2 | II. sp^3 ; pyramidal |
| C. XeOF_4 | III. sp^3d^3 ; distorted octahedral |
| D. XeF_6 | IV. sp^3d^2 ; square pyramidal |

Choose the correct answer from the options given below.

- (1) A-IV, B-II, C-I, D-III
 (2) A-II, B-I, C-IV, D-III
 (3) A-II, B-I, C-III, D-IV
 (4) A-IV, B-II, C-III, D-I

Ans. 2

82. Match List-I with List-II.

List-I

List-II

- | | |
|-------------|---------------------|
| (Example) | (Type of solution) |
| A. Humidity | I. Solid in solid |
| B. Alloys | II. Liquid in gas |
| C. Amalgam | III. Solid in gas |
| D. Smoke | IV. Liquid in solid |

Choose the correct answer from the options given below:

- (1) A-III, B-II, C-I, D-IV
 (2) A-II, B-IV, C-I, D-III
 (3) A-II, B-I, C-IV, D-III
 (4) A-III, B-I, C-IV, D-II

Ans. 3

83. Energy and radius of first bohr orbit of He^+ and Li^{2+} are

[Given $R_{11} = 2.18 \times 10^{-18} \text{ J}$, $a_0 = 52.9 \text{ pm}$]

$$E_n(\text{Li}^{2+}) = -8.72 \times 10^{-16} \text{ J};$$

(1) $r_n(\text{Li}^{2+}) = 17.6 \text{ pm}$

$$E_n(\text{He}^+) = -19.62 \times 10^{-16} \text{ J};$$

$$r_n(\text{H}^+) = 17.6 \text{ pm},$$

(2) $E_n(\text{Li}^{2+}) = -19.62 \times 10^{-18} \text{ J};$

$$r_n(\text{Li}^{2+}) = 17.6 \text{ pm}$$

$$E_n(\text{He}^+) = -8.72 \times 10^{-18} \text{ J};$$

$$r_n(\text{H}^+) = 26.4 \text{ pm},$$

$$E_n(\text{Li}^{2+}) = -8.72 \times 10^{-18} \text{ J};$$

$$r_n(\text{Li}^{2+}) = 26.4 \text{ pm}$$

(3) $E_n(\text{He}^+) = -19.62 \times 10^{-18} \text{ J};$

$$r_n(\text{H}^+) = 17.6 \text{ pm},$$

$$E_n(\text{Li}^{2+}) = -19.62 \times 10^{-16} \text{ J};$$

$$r_n(\text{Li}^{2+}) = 17.6 \text{ pm}$$

(4) $E_n(\text{He}^+) = -8.72 \times 10^{-16} \text{ J};$

$$r_n(\text{H}^+) = 26.4 \text{ pm},$$

Ans. 2

84. Which among the following electronic configurations belong to main group elements?

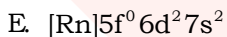
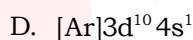
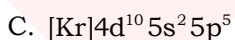
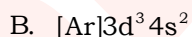

Choose the correct answer from the option given below:

(1) A, C and D only

(2) B and E only

(3) A and C only

(4) D and E only

Ans. 3

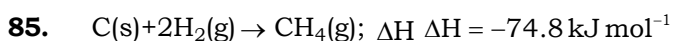

Which of the following diagrams gives an accurate representation of the above reaction?

[R \rightarrow reactants; P \rightarrow products]

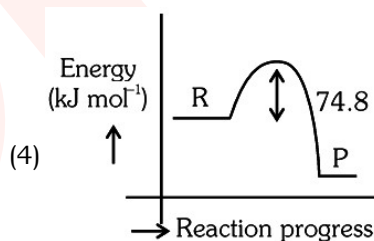
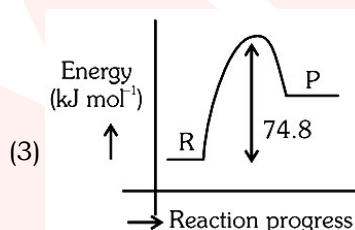
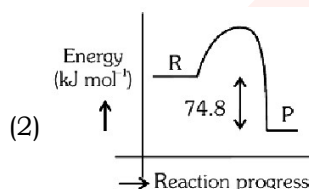
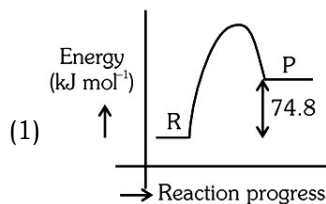

Ans. 2

86. Predist the major product 'P' in the following sequence of reactions-

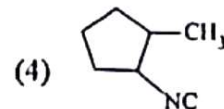
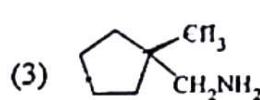
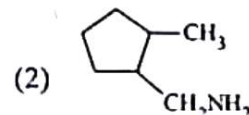
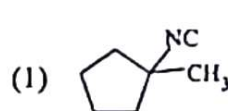
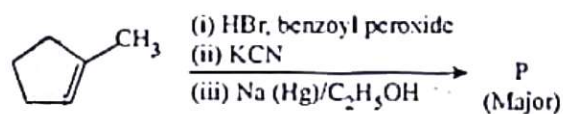

Ans. 2

87. Identify the correct orders against the property mentioned
- A. $\text{H}_2\text{O} > \text{NH}_3 > \text{CHCl}_3$ – dipole moment
 B. $\text{XeF}_4 > \text{XeO}_3 > \text{XeF}_2$ – number of lone pairs on central atom
 C. $\text{O} - \text{H} > \text{C} - \text{H} > \text{N} - \text{O}$ – bondlength
 D. $\text{N}_2 > \text{O}_2 > \text{H}_2$ – bond enthalpy
- Choose the correct answer from the options given below :
- (1) B, C only
 (2) A, D only
 (3) B, D only
 (4) A, C only

Ans. 2

88. **Total** number of possible isomers (both structural as well as stereoisomers) of cyclic ethers of molecular formula $\text{C}_4\text{H}_8\text{O}$ is :
- (1) 11
 (2) 6
 (3) 8
 (4) 10

Ans. 4

89. For the reaction $\text{A}(\text{g}) \rightleftharpoons 2\text{B}(\text{g})$, the backward reaction rate constant is higher than the forward reaction rate constant by a factor of 2500, at 1000 K.
 [Given : $R = 0.831 \text{ L atm mol}^{-1} \text{ K}^{-1}$ K_p for the reaction at 1000 K is]
- (1) 0.021
 (2) 83.1
 (3) 2.077×10^5
 (4) 0.033

Ans. 4

90. 5 mole of liquid X and 10 moles of liquid Y make a solution having a vapour pressure of 70 torr. The vapour pressures of pure X and Y are 63 torr and 78 torr respectively. Which of the following is true regarding the described solution ?
- (1) The solution has – volume greater than the sum of individual volumes

- (2) The solution shows positive deviation
 (3) The solution shows negative deviation
 (4) The solution is ideal

Ans. 3

91. Which of the following is the unit of productivity of Ecosystem ?
- (1) $(\text{Kcal m}^{-2})\text{yr}^{-1}$
 (2) gm^{-2}
 (3) KCal m^{-2}
 (4) KCal m^{-3}

Ans. 1

92. The first menstruation is called :
- (1) Ovulation
 (2) Menopause
 (3) Menarche
 (4) Diapause

Ans. 3

93. Given below are two statements: one is labelled as **Assertion (A)** and the other is labelled as **Reason (R)**.

Assertion (A): All vertebrates are chordates but all chordates are not vertebrate.

Reason (R): The members of subphylum vertebrata possess notochord during the embryonic period, the notochord is replaced by a cartilaginous or bony vertebral column in adults. In the light of the above statement, choose the correct answer from the options given below:

- (1) A is false but R is true
 (2) Both A and R are true and R is the correct explanation of A
 (3) Both A and R are true but R is not the correct explanation of A
 (4) A is true but R is false

Ans. 2

94. Genes R and Y follow independent assortment. If RRYy produce round yellow seeds and rryy produce wrinkled green seeds, what will be the phenotypic ratio of the F₂ generation ?
- (1) Phenotypic ratio - 9 : 7
 (2) Phenotypic ratio - 1 : 2 : 1
 (3) Phenotypic ratio - 3 : 1
 (4) Phenotypic ratio - 9 : 3 : 3 : 1

Ans. 4

95. Given below are two statements :

Statement-I: The DNA fragments extracted from gel electrophoresis can be used in construction of recombinant DNA.

Statement-II: Smaller size DNA fragments are observed near node while larger fragments are found near the wells in an agarose gel.

In the light of the above statements, choose the most appropriate answer from the options given below:

- (1) Statement-I is incorrect but Statement-II is correct
- (2) Both Statement-I and Statement-II are correct
- (3) Both Statement-I and Statement-II are incorrect
- (4) Statement-I is correct but Statement-II is incorrect

Ans. 2

96. What is the main function of the spindle fibres during mitosis ?

- (1) To regulate cell growth
- (2) To separate the chromosomes
- (3) To synthesize new DNA
- (4) To repair damaged DNA

Ans. 2

97. How many meiotic and mitotic divisions need to occur for the development of a mature female gametophyte from the megaspore mother cell in an angiosperm plant ?

- (1) No Meiosis and 2 Mitosis
- (2) 2 Meiosis and 3 Mitosis
- (3) 1 Meiosis and 2 Mitosis
- (4) 1 Meiosis and 3 Mitosis

Ans. 4

98. Identify the Statement that is NOT correct.

- (1) Constant region of heavy and light chains are located at C-terminus of antibody molecules.
- (2) Each antibody has two light and two heavy chains.
- (3) The heavy and light chains are held together by disulfide bonds.
- (4) Antigen binding site is located at C-terminal region of antibody molecules.

Ans. 4

99. Consider the following:

- A. The reductive division for the human female gametogenesis starts earlier than that of the male gametogenesis.
- B. The gap between the first meiotic division and the second meiotic division is much shorter for males. compared to females.

- C. The first polar body is associated with the formation of the primary oocyte.
- D. Lutcinizing Hormone (LH) surge leads to disintegration of the endometrium and onset of menstrual bleeding.

Choose the correct answer from the options given below:

- (1) B and C are true (2) A and B are true
- (3) A and C are true (4) B and D are true

Ans. 2

100. Given below are two statements: one is labelled as **Assertion (A)** and the other is labelled as **Reason (R)**.

Assertion (A): Cells of the tapetum possess dense cytoplasm and generally have more than one nucleus.

Reason (R): Presence of more than one nucleus in the tapetum increases the efficiency of nourishing the developing microspore mother cells.

In light of the above statements, choose the most appropriate answer from the options given below:

- (1) A is false but R is true
- (2) Both A and R are true and R is the correct explanation of A
- (3) Both A and R are true but R is not the correct explanation of A
- (4) A is true but R is false

Ans. 2

101. The blue and white selectable markers have been developed which differentiate recombinant colonies from non-recombinant colonies on the basis of their ability to produce colour in the presence of a chromogenic substrate.

Given below are two statements about this method:

Statement-I The blue coloured colonies have DNA insert in the plasmid and they are identified as recombinant colonies.

Statement-II: The colonies without blue colour have DNA insert in the plasmid and are identified as recombinant colonies.

In the light of the above statements, choose the **most appropriate** answer from the options given below:

- (1) Statement-I is incorrect but Statement-II is correct
- (2) Both Statement-I and Statement-II are correct
- (3) Both Statement-I and Statement-II are incorrect
- (4) Statement-I is correct but Statement-II is incorrect

Ans. 1

102. In bryophytes, the gemmae help in which one of the following ?
- (1) Gaseous exchange
 - (2) Sexual reproduction
 - (3) Asexual reproduction
 - (4) Nutrient absorption

Ans. 3

103. Match List-I with List-II.

List-I	List-II
A. Adenosine	I. Nitrogen base
B. Adenylic acid	II. Nucleotide
C. Adenine	III. Nucleoside
D. Alanine	IV. Amino acid

Choose the option with all correct matches.

- (1) A-II, B-III, C-I, D-IV
- (2) A-III, B-IV, C-II, D-I
- (3) A-III, B-II, C-IV, D-I
- (4) A-III, B-II, C-I, D-IV

Ans. 4

104. With the help of given pedigree, find out the probability for the birth of a child having no disease and being a carrier (has the disease mutation in one allele of the gene) in F₃ generation.

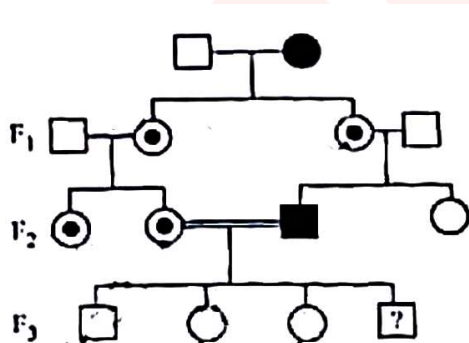

- Unaffected male
- Affected male
- ⊙ Carrier female
- Unaffected female
- Affected female

- (1) Zero
- (2) 1/4
- (3) 1/2
- (4) 1/8

Ans. 2 & 3

105. Consider the following statements regarding function of adrenal medullary hormones.
- A. It causes pupillary constriction
 - B. It is a hyperglycemic hormone
 - C. It causes piloerection
 - D. It increases strength of heart contraction
- Choose the correct answer from the options given below:

- (1) D only
- (2) C and D only
- (3) B, C and D only
- (4) A, C and D only

Ans. 3

106. Which of the following is an example of a zygomorphic flower ?

- (1) Chilli
- (2) Petunia
- (3) Datura
- (4) Pea

Ans. 4

107. Who proposed that the genetic code for amino acids should be made up of three nucleotides ?

- (1) Franklin Stahl
- (2) George Gamow
- (3) Francis Crick
- (4) Jacques Monod

Ans. 2

108. Given below are two statements:

Statement-I: In ecosystem, there is unidirectional flow of energy of sun from producers to consumers.

Statement-II: Ecosystems are exempted from 2nd law of thermodynamics.

In the light of the above statements, choose the **most appropriate** answer from the options given below:

- (1) Statement-I is incorrect but Statement-II is correct
- (2) Both Statement-I and Statement-II are correct
- (3) Both Statement-I and Statement-II are incorrect
- (4) Statement-I is correct but Statement-II is incorrect

Ans. 4

109. Sweet potato and potato represent a certain type of evolution. Select the correct combination of terms to explain the evolution.

- (1) Analogy, divergent
- (2) Analogy, convergent
- (3) Homology, divergent
- (4) Homology, convergent

Ans. 2

110. All living members of the class Cyclostomata are:

- (1) Ectoparasite
- (2) Free living
- (3) Endoparasite
- (4) Symbiotic

Ans. 1

111. Histones are enriched with -

- (1) Phenylalanine and Arginine
- (2) Lysine and Arginine
- (3) Leucine and Lysine
- (4) Phenylalanine Leucine

Ans. 2

112. Which one of the following equations represents the Verhulst-Pearl Logistic Growth of population ?

$$(1) \frac{dN}{dt} = N \left(\frac{r + K}{K} \right)$$

$$(2) \frac{dN}{dt} = r \left(\frac{K - N}{K} \right)$$

$$(3) \frac{dN}{dt} = rN \left(\frac{K - N}{K} \right)$$

$$(4) \frac{dN}{dt} = rN \left(\frac{K - N}{N} \right)$$

Ans. 3

113. Given below are two statements: one is labelled as **Assertion (A)** and the other is labelled as **Reason (R)**.

Assertion (A): The primary function of the Golgi apparatus is to package the materials made by the endoplasmic reticulum and deliver it to intracellular targets and outside the cell.

Reason (R): Vesicles containing materials made by the endoplasmic reticulum fuse with the cis face of the Golgi apparatus, and they are modified and released from the trans face of the

Golgi apparatus.

In light of the above statements, choose the **correct** answer from the options given below:

- (1) A is false but R is true
- (2) Both A and R are true and R is the correct explanation of A
- (3) Both A and R are true but R is not the correct explanation of A
- (4) A is true but R is false

Ans. 2

114. Which of the following statements about RuBisCO is true ?

- (1) It catalyzes the carboxylation of RuBP.
- (2) It is active only in the dark.
- (3) It has higher affinity for oxygen than carbon dioxide.
- (4) It is an enzyme involved in the photolysis of water.

Ans. 1

115. Match List-I with List-II:

(1)

List-I

List-II

- | | |
|-----------------------------------|----------------------|
| A. Progesterone | I. Pars intermedia |
| B. Relaxin | II. Ovary |
| C. Melanocyte stimulating hormone | III. Adrenal medulla |
| D. Catecholamines | IV. Corpus luteum |
- Choose the **correct** answer from the options given below:

- (1) A-III, B-II, C-IV, D-I
- (2) A-IV, B-II, C-I, D-III
- (3) A-IV, B-II, C-III, D-I
- (4) A-II, B-IV, C-I, D-III

Ans. 2

116. The protein portion of an enzyme is called:

- (1) Prosthetic group
- (2) Cofactor
- (3) Coenzyme
- (4) Apoenzyme

Ans. 4

117. Which of the following enzyme(s) are NOT essential for gene cloning ?
- Restriction enzymes
 - DNA ligase
 - DNA mutase
 - DNA recombinase
 - DNA polymerase

Choose the **correct** answer from the options given below:

- (1) B and C only (2) C and D only
(3) A and B only (4) D and E only

Ans. 2

118. Which of the following type of immunity is present at the time of birth and is a non-specific type of defence in the human body ?

- Humoral Immunity
- Acquired Immunity
- Innate Immunity
- Cell-mediated Immunity

Ans. 3

119. Which factor is important for termination of transcription ?

- (1) γ (gamma) (2) α (alpha)
(3) σ (sigma) (4) ρ (rho)

Ans. 4

120. Which of the following hormones released from the pituitary is actually synthesized in the hypothalamus ?

- Adenocorticotrophic hormone (ACTH)
- Luteinizing hormone (LH)
- Anti-diuretic hormone (ADH)
- Follicle-stimulating hormone (FSH)

Ans. 3

121. Which of the following microbes is NOT involved in the preparation of household products ?

- Aspergillus niger
- Lactobacillus
- Trichoderma polysporum
- Saccharomyces cerevisiae
- Propionibacterium sharmani

Choose the **correct** answer from the options given below:

- (1) C and E only (2) A and B only
(3) A and C only (4) C and D only

Ans. 3

122. Given below are two statements:

Statement-I: Fig fruit is a non-vegetarian fruit as it has enclosed fig wasps in it.

Statement-II: Fig wasp and fig tree exhibit mutual relationship as fig wasp completes its life cycle in fig fruit and fig fruit gets pollinated by fig wasp.

In the light of the above statements, choose the **most appropriate** answer from the options given below:

- Statement-I is incorrect but Statement-II is correct
- Both Statement-I and Statement-II are correct
- Both Statement-I and Statement-II are incorrect
- Statement-I is correct but Statement-II is incorrect

Ans. 3

123. Role of the water vascular system in Echinoderms is :

- Respiration and Locomotion
- Excretion and Locomotion
- Capture and transport of food
- Digestion and Respiration
- Digestion and Excretion

Choose the **correct** answer from the options given below:

- B, D and E only
- A and B only
- A and C only
- B and C only

Ans. 3

124. After maturation, in primary lymphoid organs, the lymphocytes migrate for interaction with antigens to secondary lymphoid organ(s)/ tissue(s) like:

- thymus B. bone marrow
- spleen D. lymph nodes
- Peyer's patches

Choose the **correct** answer from the options given below:

- C, D and E only
- B, C and D only
- A, B and C only
- E, A and B only

Ans. 1

125. Match List-I with List-II:

List-I	List-II
A. The Evil Quartet	I. Cryopreservation
B. Ex situ conservation	II. Alien species invasion
C. Lantana	III. Causes of biodiversity losses
D. Dodo	IV. Extinction

Choose the option with all correct matches.

- (1) A-III, B-II, C-IV, D-I
- (2) A-III, B-II, C-I, D-IV
- (3) A-III, B-I, C-II, D-IV
- (4) A-III, B-IV, C-II, D-I

Ans. 3

126. Read the following statements on plant growth and development.

- A. Parthenocarpy can be induced by auxins.
- B. Plant growth regulators can be involved in promotion as well as inhibition of growth.
- C. Dedifferentiation is a pre-requisite for re-differentiation.
- D. Abscisic acid is a plant growth promoter.
- E. Apical dominance promotes the growth of lateral buds.

Choose the option with all correct statements.

- (1) B, D and E only
- (2) A, B and C only
- (3) A, C and E only
- (4) A, D and E only

Ans. 2

127. Match List-I with List-II.

List-I	List-II
A. Pteridophyte	I. Salvia
B. Bryophyte	II. Ginkgo
C. Angiosperm	III. Polytrichum
D. Gymnosperm	IV. Salvinia

Choose the options with all **correct** matches.

- (1) A-IV, B-III, C-II, D-I
- (2) A-III, B-IV, C-II, D-I
- (3) A-IV, B-III, C-I, D-II
- (4) A-III, B-IV, C-I, D-II

Ans. 3

128. Why can't insulin be given orally to diabetic patients ?

- (1) Its bioavailability will be increased
- (2) Human body will elicit strong immune response
- (3) It will be digested in Gastro-Intestinal (GI) tract
- (4) Because of structural variation

Ans. 3

129. Which of the following is the characteristic feature of gymnosperms ?

- (1) Gymnosperms have flowers for reproduction.
- (2) Seeds are enclosed in fruits.
- (3) Seeds are naked.
- (4) Seeds are absent.

Ans. 3

130. Frogs respire in water by skin and buccal cavity and on land by skin, buccal cavity and lungs. Choose the correct answer from the following:

- (1) The statement is false for both the environment
- (2) The statement is true for water but false for land
- (3) The statement is true for both the environment
- (4) The statement is false for water but true for land

Ans. 4

131. Silencing of specific mRNA is possible via RNAi because of :

- (1) Non-complementary ssRNA
- (2) Complementary dsRNA
- (3) Inhibitory ssRNA
- (4) Complementary tRNA

Ans. 2

132. Twins are born to a family that lives next door to you. The twins are a boy and a girl. Which of the following must be true.

- (1) They have 75% identical genetic content
- (2) They are monozygotic twins
- (3) They are fraternal twins
- (4) They were conceived through in vitro fertilization

Ans. 3

133. Match List - I with List - II

List - I

- A. Scutellum
- B. Non-albuminous seed
- C. Epiblast
- D. Perisperm

List - II

- I. Persistent nucellus
- II. Cotyledon of monocot seed
- III. Groundnut
- IV. Rudimentary cotyledon

Choose the option with all correct matches

- (1) A - II, B-IV, C-III, D - I
- (2) A - II, B - III, C - IV, D - I
- (3) A - IV, B -III, C-II, D -I
- (4) A-IV, B-III, C-I, D -II

Ans. 2

134. In frog, the Renal portal system is a specific venous connection that acts to link

- (1) Kidney and lower part of body
- (2) Liver and intestine
- (3) Liver and kidney
- (4) Kidney and intestine

Ans. 1

135. Match List-I with List- II

List - I

- A. Heart
- B. Kidney
- C. Gastro-intestinal tract
- D. Adrenal cortex

List -II

- I. Erythropoietin
- II. Aldosterone
- III. Atrial natriuretic factor
- IV. Secretin

Choose the correct answer from the option given below

- (1) A-III, B-I, C-IV, D-II
- (2) A-II, B-I, C-II, D -IV
- (3) A-IV, B-III, C-II, D-I
- (4) A-I, B-III, C-IV, D-II

Ans. 1

136. Cardiac activities of the heart are regulated by:

- A. Nodal tissue
- B. A special neural centre in the medulla oblongata
- C. Adrenal medullary hormones
- D. Adrenal cortical hormones

Choose the correct answer from the options given below :

- (1) A, B and D only
- (2) A, B and C only
- (3) A, B, C and D
- (4) A, C and D only

Ans. (2)

137. Streptokinase produced by *bacterium Streptococcus* is used for

- (1) Removing clots from blood vessels
- (2) Curd production
- (3) Ethanol production
- (4) Liver disease treatment

Ans. 1

138. Who is known as the father of Ecology in India ?

- (1) Birbal Sahni
- (2) S.R. Kashyap
- (3) Ramdeo Mishra
- (4) Ram Udar

Ans. 3

139. Given below are two statements : One is labelled as Assertion (A) and the other is labelled as Reason (R) :

Assertion (A) : A typical unfertilised angiosperm embryo at maturity is 8 nucleate and 7-celled.

Reason (R) : The egg apparatus has 2 polar nuclei.

In the light of the above statements, choose the correct answer from the options given below :

- (1) A is false but R is true
- (2) Both A and R are true and R is the correct explanation of A.
- (3) Both A and R are true but R is NOT the correct explanation of A.
- (4) A is true but R is false.

Ans. 4

140. Neoplastic characteristics of cells refer to :
- A mass of proliferating cell
 - Rapid growth of cells
 - Invasion and damage to the surrounding tissue
 - Those confined to original location
- Choose the correct answer from the options given below.
- B, C, D only
 - A, B only
 - A, B, C only
 - A, B, D only

Ans. 3

141. Given below are the stages in the life cycle of pteridophytes. Arrange the following stages in the correct sequence.
- Prothallus stage
 - Meiosis in spore mother cells
 - Fertilisation
 - Formation of archegonia and antheridia in gametophyte.
 - Transfer of antherozoids to the archegonia in presence of water.
- Choose the correct answer from the options given below.
- E, D, C, B, A
 - B, A, D, E, C
 - B, A, E, C, D
 - D, E, C, A, B

Ans. 2

142. Given below are two statements : One is labelled as Assertion (A) and the other is labelled as Reason (R).
- Assertion (A) :** Both wind and water pollinated flowers are not very colourful and do not produce nectar.
- Reason(R) :** The flowers produce enormous amount of pollen grains in wind and water pollinated flowers.
- In the light of the above statements, choose the correct answer from the options given below :
- A is false but R is true
 - Both A and R are true and R is the correct explanation of A

- Both A and R are true but R is NOT the correct explanation of A
- A is true but R is false

Ans. 3

143. Which one of the following enzymes contains 'Haem' as the prosthetic group ?
- Catalase
 - RuB is Co
 - Carbonic anhydrase
 - Succinate dehydrogenase

Ans. 1

144. Match List-I with List -II.

List-I		List-II	
A.	Emphysema	I.	Rapid spasms in muscle due to low Ca^{++} in body fluid
B.	Angina Pectoris	II.	Damaged alveolar walls and decreased respiratory surface
C.	Glomerulo nephritis	III.	Acute chest pain when not enough oxygen is reaching to heart muscle
D.	Tetany	IV.	Inflammation of glomeruli of kidney

Choose the correct answer from the options given below :

- A-II, B-III, C-IV, D-I
- A-III, B-I, C-IV, D-II
- A-III, B-I, C-II, D-IV
- A-II, B-IV, C-III, D-I

Ans. 1

145. Find the statement that is NOT correct with regard to the structure of monocot stem.
- Phloem parenchyma is absent.
 - Hypodermis is parenchymatous.
 - Vascular bundles are scattered.
 - Vascular bundles are conjoint and closed.

Ans. 2

146. Which of the following statement is correct about location of the male frog copulatory pad ?
- (1) First digit of the fore limb
 - (2) First and Second digit of fore limb
 - (3) First digit of hind limb
 - (4) Second digit of fore limb

Ans. 1

147. Given below are two statements :

Statement I : The primary source of energy in an ecosystem is solar energy

Statement II : The rate of production of organic matter during photosynthesis in an ecosystem is called net primary productivity (NPP).

In the light of the above statements choose the most appropriate answer from the options given below :

- (1) Statement I is incorrect but statement II is correct
- (2) Both statement I and statement II are correct
- (3) Both statement I and statement II are incorrect
- (4) Statement I is correct but statement II is incorrect

Ans. 4

148. Identify the part of a bio-reactor which is used as a foam breaker from the given figure.

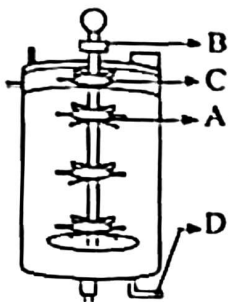

- (1) C
- (2) A
- (3) B
- (4) D

Ans. 1

149. Polymerase chain reaction (PCR) amplifies DNA following the equation.

- (1) $2N^2$
- (2) N^2
- (3) 2^n
- (4) $2n + 1$

Ans. 3

150. Match List-I with List-II.

List-I		List-II	
A.	Head	I.	Enzyme
B.	Middle piece	II.	Sperm motility
C.	Acrosome	III.	Energy
D.	Tail	IV.	Genetic material

Choose the correct answer from the options given below :

- (1) A-III, B-II, C-I, D-IV
- (2) A-IV, B-III, C-I, D-II
- (3) A-IV, B-III, C-II, D-I
- (4) A-III, B-IV, C-II, D-I

Ans. 2

151. Given below are two statements :

Statement I : In a floral formula \oplus stands for zygomorphic nature of the flower and \underline{G} stands for inferior ovary.

Statement II : In a floral formula \oplus stands for actinomorphic nature of the flower and \underline{G} stands for superior ovary.

In the light of the above statements, choose the correct answer from the options given below :

- (1) Statement I is incorrect but Statement II is correct
- (2) Both Statement I and Statement II are correct
- (3) Both Statement I and Statement II are incorrect
- (4) Statement I is correct but Statement II is incorrect

Ans. 1

152. From the statement given below choose the correct option :

- A. The eukaryotic ribosomes are 80S and prokaryotic ribosomes are 70S.
- B. Each ribosome has two sub-units.
- C. The two sub-units of 80S ribosome are 60S and 40S while that of 70S are 50S and 30S.
- D. The two sub-units of 80S ribosome are 60S and 20S and that of 70S are 50S and 20S.
- E. The two sub-units of 80S are 60S and 30S and that of 70S are 50S and 30S.

- (1) B, D, E are true (2) A, B, C are true
(3) A, B, D are true (4) A, B, E are true

Ans. 2

153. Each of the following characteristics represent a Kingdom proposed by Whittaker. Arrange the following in increasing order of complexity of body organization.

- A. Multicellular heterotrophs with cell wall made of chitin.
- B. Heterotrophs with tissue/organ/organ system level of body organization.
- C. Prokaryotes with cell wall made of polysaccharides and amino acids.
- D. Eukaryotic autotrophs with tissue/organ level of body organization.
- E. Eukaryotes with cellular body organization.

Choose the correct answer from the options given below :

- (1) C, E, A, B, D (2) A, C, E, B, D
(3) C, E, A, D, B (4) A, C, E, D, B

Ans. 3

154. The correct sequence of events in the life cycle of bryophytes is

- A. Fusion of antherozoid with egg.
- B. Attachment of gametophyte to substratum.
- C. Reduction division to produce haploid spores.
- D. Formation of sporophyte.
- E. Release of antherozoids into water.

Choose the correct answer from the options given below :

- (1) D, E, A, B, C (2) D, E, A, C, B
(3) B, E, A, C, D (4) B, E, A, D, C

Ans. 4

155. Which are correct :

- A. Computed tomography and magnetic resonance imaging detect cancers of internal organs.
- B. Chemotherapeutic drugs are used to kill non-cancerous cells.
- C. α -interferon activate the cancer patients immune system and helps in destroying the tumour.
- D. Chemotherapeutic drugs are biological response modifiers.
- E. In the case of leukaemia blood cell counts are decreased.

Choose the correct answer from the options given below :

- (1) A and C only (2) B and D only
(3) D and E only (4) C and D only

Ans. 1

156. Name the class of enzyme that usually catalyze the following reaction :

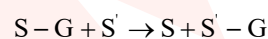

Where G : a group other than hydrogen

S : a substrate

S' : another substrate

- (1) Ligase (2) Hydrolase
(3) Lyase (4) Transferase

Ans. 4

157. Find the correct statements :

- A. In human pregnancy, the major organ systems are formed at the end of 12 weeks.
- B. In human pregnancy the major organ systems are formed at the end of 8 weeks.
- C. In human pregnancy heart is formed after one month of gestation.
- D. In human pregnancy, limbs and digits develop by the end of second month.
- E. In human pregnancy the appearance of hair is usually observed in the fifth month.

Choose the correct answer from the options given below :

- (1) A, C, D and E only
(2) A and E only
(3) B and C only
(4) B, C, D and E only

Ans. 1

158. Which of the following is an example of non-distilled alcoholic beverage produced by yeast ?
- (1) Rum (2) Whisky
(3) Brandy (4) Beer

Ans. 4

159. Given below are two statements :

Statement I : In the RNA world. RNA is considered the first genetic material evolved to carry out essential life processes. RNA acts as a genetic material and also as a catalyst for some important biochemical reactions in living systems. Being reactive. RNA is unstable.

Statement II : DNA evolved from RNA and is a more stable genetic material. Its double helical strands being complementary, resist changes by evolving repairing mechanism.

In the light of the above statements choose the most appropriate answer from the options given below :

- (1) Statement I is incorrect but statement II is correct
(2) Both statement I and statement II are correct
(3) Both statements I and statement II are incorrect
(4) Statement I is correct but statement II is incorrect

Ans. 2

160. Given below are two statements :

Statement I : Transfer RNAs and ribosomal RNA do not interact with mRNA.

Statement II : RNA interference (RNAi) takes place in all eukaryotic organisms as a method of cellular defence.

In the light of the above statements choose the most appropriate answer from the options given below :

- (1) Statement I is incorrect but Statement II is correct
(2) Both Statement I and Statement II are correct
(3) Both Statement I and Statement II are incorrect
(4) Statement I is correct but Statement II is incorrect

Ans. 1

161. Which of the following diagrams is correct with regard to the proximal (P) and distal (D) tubule of the Nephron.

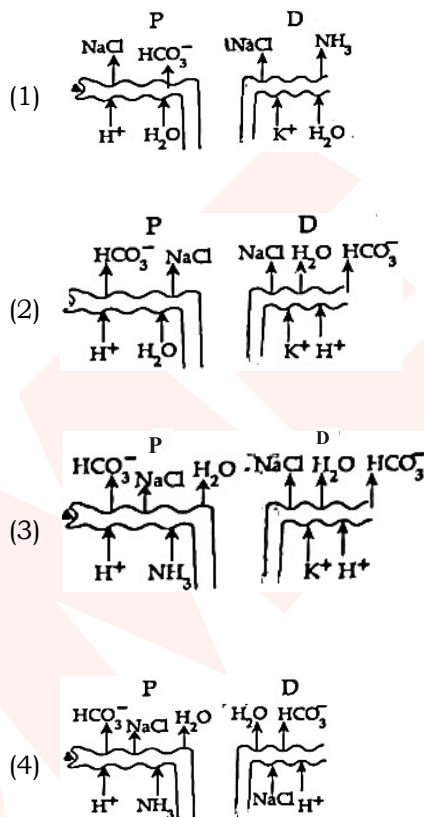

Ans. 3

162. What is the pattern of inheritance for polygenic trait ?

- (1) X-linked recessive inheritance pattern
(2) Mendelian inheritance Pattern
(3) Non-mendelian inheritance pattern
(4) Autosomal dominant pattern

Ans. 3

163. In the seeds of cereals, the outer covering of endosperm separates the embryo by a protein rich layer called :

- (1) Aleurone layer
(2) Coleoptile
(3) Coleorhiza
(4) Integument

Ans. 1

164. Match List I with List II :

List-I		List-II	
A.	Chlorophyll a	I.	Yellow green
B.	Chlorophyll b	II.	Yellow
C.	Xanthophylls	III.	Blue green
D.	Carotenoids	IV.	Yellow to Yellow orange

Choose the option with all correct matches.

- (1) A-I, B-IV, C-III, D-II
- (2) A-III, B-IV, C-II, D-I
- (3) A-III, B-I, C-II, D-IV
- (4) A-I, B-II, C-IV, D-III

Ans. 3

165. Which of the following genetically engineered organisms was used by Eli Lilly to prepare human insulin ?

- (1) Phase
- (2) Bacterium
- (3) Yeast
- (4) Virus

Ans. 2

166. Which of the following are the post transcriptional events in an eukaryotic cell ?

- A. Transport of pre-mRNA to cytoplasm prior to splicing.
- B. Removal of introns and joining of exons.
- C. Addition of methyl group at 5' end of hnRNA.
- D. Addition of adenine residues at 3' end of hnRNA.
- E. Base pairing of two complementary RNAs.

Choose the correct answer from the options given below :

- (1) C, D, E only
- (2) A, B, C only
- (3) B, C, D only
- (4) B, C, E only

Ans. 3

167. Match List-I with List-II.

List-I		List-II	
A.	Centromere	I.	Mitochondrion
B.	Cilium	II.	Cell division
C.	Cristae	III.	Cell movement
D.	Cell membrane	IV.	Phospholipid Bilayer

Choose the correct answer from the options given below :

- (1) A-II, B-III, C-I, D-IV
- (2) A-I, B-II, C-III, D-IV
- (3) A-II, B-I, C-IV, D-III
- (4) A-IV, B-II, C-III, D-I

Ans. 1

168. Match List I with List II :

List-I		List-II	
A.	Alfred Hershey and Martha Chase	I.	Streptococcus pneumonia
B.	Euchromatin	II.	Densely packed and dark-stained
C.	Frederick Griffith	III.	Loosely packed and light-stained
D.	Heterochromatin	IV.	DNA as genetic material confirmation

Choose the correct answer from the options given below :

- (1) A-III, B-II, C-IV, D-I
- (2) A-II, B-IV, C-I, D-III
- (3) A-IV, B-II, C-I, D-III
- (4) A-IV, B-III, C-I, D-II

Ans. 4

169. Which chromosome in the human genome has the highest number of genes ?
- (1) Chromosome 10
 - (2) Chromosome X
 - (3) Chromosome Y
 - (4) Chromosome 1

Ans. 4

170. What are the potential drawbacks in adaptation of the IVF method ?
- A. Light fatality risk mother
 - B. Expensive instrument and reagents
 - C. Husbands/ wife necessary for being donors
 - D. Less adoption nephrons
 - E. Not available in India
 - F. Possibility that the early embryo does not survive

Choose the correct answer from the option given below

- (1) A, B, C, E, F only
- (2) B, D, F only
- (3) A, C, D, F only
- (4) A, B, C, D only

Ans. 2

171. Which one of the following is an example of ex-situ conservation ?
- (1) Protected areas
 - (2) National Park
 - (3) Wildlife Sanctuary
 - (4) Zoos and botanical gardens

Ans. 4

172. A specialised membranous structure in a prokaryotic cell which helps in cell wall formation, DNA replication and respiration is :
- (1) Endoplasmic Reticulum
 - (2) Mesosome
 - (3) Chromatophores
 - (4) Cristae

Ans. 2

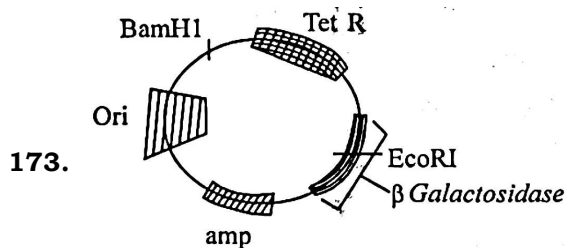

In the above represents plasmid an alien piece of DNA is inserted at EcoRI site. Which of the following strategies will be chosen to select the recombinant colonies ?

- (1) Blue color colonies grown on ampicillin plates can be selected
- (2) Using ampicillin and tetracycline containing medium plate
- (3) Blue color colonies will be selected
- (4) White color colonies will be selected.

Ans. 4

174. What is the name of the blood vessel that carries deoxygenated blood from the body to the heart in a frog ?

- (1) Vena cava
- (2) Aorta
- (3) Pulmonary artery
- (4) Pulmonary vein

Ans. 1

175. Which of the following organisms cannot fix nitrogen
- | | |
|----------------|-----------------|
| A. Azotobacter | B. Oscillatoria |
| B. Anabaena | D. Volvox |
| E. Nostoc | |

Choose the correct answer from the options given below

- | | |
|------------|------------|
| (1) E only | (2) A only |
| (3) D only | (4) B only |

Ans. 3

- 176.** While trying to find out the characteristic of a newly found animal, a researcher did the histology of adult animal and observed a cavity with presence of mesodermal tissue towards the body wall but no mesodermal tissue was observed towards the alimentary canal. What could be the possible coelome of that animal ?
- (1) Spongocoelomate
 - (2) Acoelomate
 - (3) Pseudocoelomate
 - (4) Schizocoelomate

Ans. 3

- 177.** Which one of the following statements refers to Reductionist Biology ?
- (1) Behavioural approach to study and understand living organisms
 - (2) Physico-chemical approach to study and understand living organisms
 - (3) Physiological approach to study and understand living organisms
 - (4) Chemical approach to study and understand living organisms

Ans. 2

- 178.** Epiphyts that are growing on a mango branch is an example of which of the following ?
- (1) Amensalism
 - (2) Commensalism
 - (3) Mutualism
 - (4) Predation

Ans. 2

- 179.** Which one of the following phytohormones promotes nutrient mobilization which helps in the delay of leaf senescence plants
- (1) Cytokinin
 - (2) Ethylene
 - (3) Abscisic acid
 - (4) Gibberellin

Ans. 1

- 180.** These complex II of mitochondrial electron transport chain is also known as
- (1) NADH dehydrogenase
 - (2) Cytochrome bc
 - (3) Succinate dehydrogenase
 - (4) Cytochrome c oxidase

Ans. 3

सिर्फ मेडिकल Preparation का संस्थान

हम सभी अभिभावकों और छात्रों के निरंतर
समर्थन और विश्वास के लिए आभारी हैं।



एक शहर, एक संस्थान और **25** बैच की एकसाथ शुरुआत



Batches Starting from

15th May, 2025

Admission-cum-Scholarship Test

for NEET 2026/2027

Test Date

8th, 9th, 10th & 11th May

FOUNDATION

(11th moving students)
For NEET 2027

FRESHER

(12th moving students)
For NEET 2026

TARGET

(12th passed students)
For NEET 2026

PRE-FOUNDATION

9th & 10th
moving students



SCAN this
QR CODE &
Register for
OFFLINE
SCHOLARSHIP
TEST

7360066185 / 86 / 87 / 88 / 89 / 90 / 91 / 92

Shivpuri (Kilburn Colony)
Opp. Spring City Mall, Hinoo, Ranchi

New Nagratoli, Near Women's
College, Science Block, Ranchi

BARIATU : (Classroom Campus) - Chhotanagpur Public
School, Beside Medica Hospital, Booti More, Ranchi

www.biomeinstitute.in [youtube.com/biomeinstitute](https://www.youtube.com/biomeinstitute) [facebook.com/biomeinstitute/](https://www.facebook.com/biomeinstitute/)

LIBRARY HOSTEL TRANSPORT
Manage by third party